



Catalogo parti di ricambio
Spare parts catalogue
Ersatzteilkatalog
Catalogue pieces detachees
Catalogo de repuestos

Model:..... **SUPERMAGNUM VX 304**

Code:..... **1121090810**

Valid from: **01/09/2018**

INDEX

Table	Model	pag.
1	SUPERMAGNUM VX_01	4
2	VX304_00	6
3		
4		
5		
6		
7		
8		
9		
10		

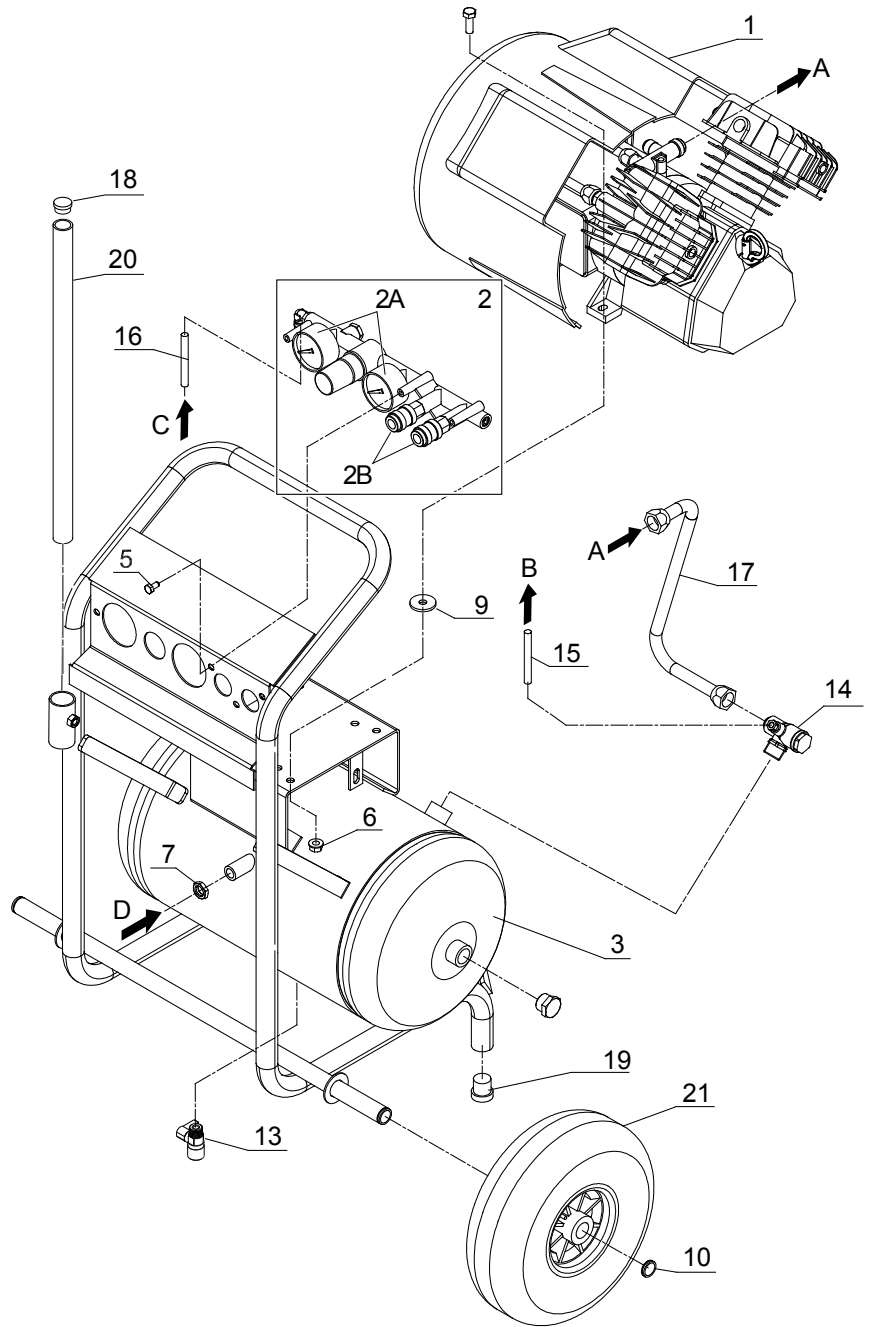
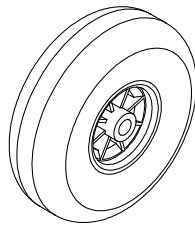
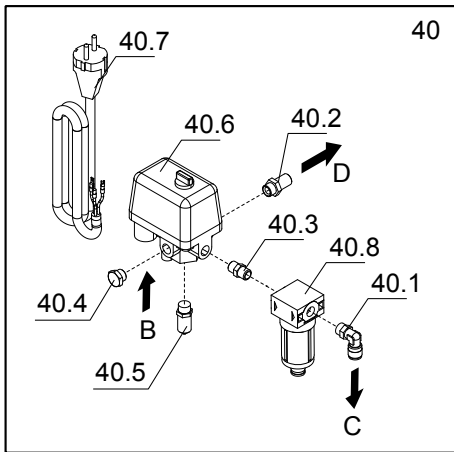



Model: SUPERMAGNUM VX 304
 Code: 1121090810
 Valid from: 01/09/2018
 Tav.: SUPERMAGNUM VX_01

N°	Code	Q.ty	Q.ty*	Description	N°	Code	Q.ty	Q.ty*	Description
1	1122020700	1		GRUPPO VX304 unit					
2	1124140033	1		KIT CRUSCOTTO INSTRUMENTS PANEL KIT					
2a	1127110030	2	20	MANOMETRO PRESSURE GAUGE					
2b	1127130057	2		RUBINETTO UNIVERSALE TAP					
3	1125150079	1		SERBATOIO TANK					
5	1127010192	4		VITE SCREW					
6	1127020024	5		DADO NUT					
7	1127020304	1		CONTRODADO LOCK NUT					
9	1127360046	4		GOMMINO RUBBER FOOT					
10	1127040202	2		SEEGER INTERNAL SNAPRING					
13	1127130016	1	20	RUBINETTO SPURGO DISCHARGE TAP					
14	1127190019	1	20	VALVOLA DI RITEGNO CHECK VALVE					
15	1127230001	0,2		TUBO RILSAN RILSAN TUBE					
16	1127230008	0,5		TUBO RILSAN RILSAN TUBE					
17	1127230636	1		TUBO ALIMENTAZIONE INFEEED HOSE					
18	1127360019	1		GOMMINO RUBBER FOOT					
19	1127360004	2		PIEDE IN GOMMA RUBBER FOOT					
20	1127390848	1		MANICO HANDLE					
21	1127260047	2		RUOTA WHEEL					
40	1124050834	1		KIT PRESSOSTATO PRESS. SWITCH KIT					
40.1	1127080097	1		RACCORDO FITTING					
40.2	1127080114	1		RACCORDO FITTING					
40.3	1127080012	1		RACCORDO FITTING					
40.4	1127090007	1		TAPPO PLUG					
40.5	1127190201	1	20	VALVOLA DI SIC. RELIEF VALVE					
40.6	1127250002	1	20	PRESSOSTATO PRESSURE SWITCH					
40.7	1127320907	1		CAVO ALIMENTAZIONE POWER CABLE					
40.8	1127100052	1		FILTRO CONDENSA FILTER					

Q.ty = Quantità unitaria / Single unit quantity / Quantité unitaire / Cantidad unitaria / Einzeleinheitsmenge

Q.ty* = Ricambi consigliati in percentuale / Suggested spare parts in percentage / Pièces de rechange suggérées en pourcentage / Piezas de repuesto sugeridas en porcentaje / Vorgeschlagene Ersatzteile in Prozent

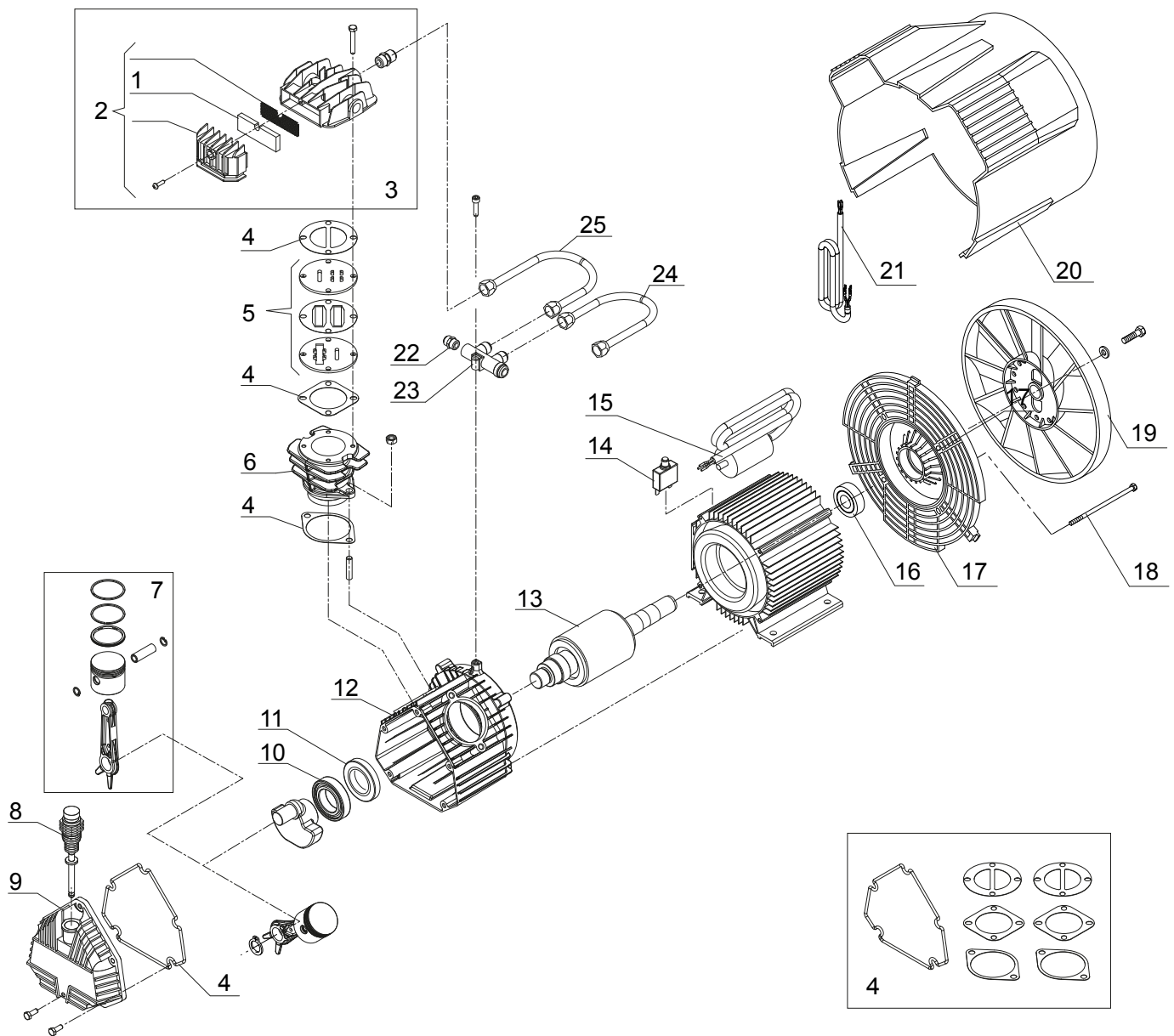



Model: SUPERMAGNUM VX 304
Code: 1121090810
Valid from: 01/09/2018
Tav.: VX304_00

N°	Code	Q.ty	Q.ty*	Description	N°	Code	Q.ty	Q.ty*	Description
1	1127210001	2	30	ELEMENTO FILTRANTE FILTER CARTRIDGE					
2	1124080700	1		KIT FILTRO KIT					
3	1124020087	1		KIT TESTA HEAD KIT					
4	1124080208	2	30	KIT GUARNIZIONI GASKETS KIT					
5	1127450949	2	30	PIASTRA VALVOLE VALVE PLATE					
6	1125060016	2		CILINDRO CYLINDER					
7	1124190104	2	30	KIT BIELLA/PISTONE CON ROD-PISTON KIT					
8	1127180106	1		ASTA LIVELLO OLIO OIL DIPSTICK					
9	1127650001	1		COPERCHIO CARTER CASING COVER					
10	1127060007	1		CUSCINETTO 6007 BEARING					
11	1127070116	1		ANELLO SMIM 4062/10 RING					
12	1125070018	1		CARTER CRANKCASE					
13	1124280086	1		INDOTTO MONOFASE TRADUZIONE MANCANTE					
14	1127410039	1		TERMICA MONOFASE 15 AMP CIRCUIT BREAKER					
15	1127310041	1		CONDENSATORE 50 MF CAPACITOR					
16	1127060003	1		CUSCINETTO 6204 2RS BEARING					
17	1127640001	1		CALOTTA COVER					
18	1127010510	4		TIRANTE TIE-ROD					
19	1127200034	1		VENTOLA FAN					
20	1127150037	1		CARENATURA HOUSING					
21	1127320990	1		CAVO MONOFASE CABLE					
22	1127190600	1		VALVOLA START START VALVE					
23	1127080995	1		COLLETTORE MANIFOLD					
24	1127230701	1		TUBO DX. PIPE					
25	1127230702	1		TUBO SX. PIPE					

Q.ty = Quantità unitaria / Single unit quantity / Quantité unitaire / Cantidad unitaria / Einzeleinheitsmenge
Q.ty* = Ricambi consigliati in percentuale / Suggested spare parts in percentage / Pièces de rechange suggérées en pourcentage / Piezas de repuesto sugeridas en porcentaje / Vorgeschlagene Ersatzteile in Prozent